



CGEO INTERNATIONAL LIMITED

Model CGEO-SG2

Vibrating Wire Strain Gauge

Installation Manual

(REV B)

CONTENTS

	Page
1. INTRODUCTION.....	1
2. INSTRUMENT INSTALLATION	1
2.1. Initial Inspection.....	1
2.2. Installing the CGEO-SG2 Strain Gauge.....	2
2.3. Adjusting the Strain Gauge	4
2.4. Notice	5
2.5. Thunder-proof Protections	5
3. READINGS AND COMPUTATION	5
4. STRAIN-STRESS CONVERSION	6
5. TROUBLESHOOTING	9
APPENDIX A	10
APPENDIX B	11

1. INTRODUCTION

The CGEO-SG2 Vibrating Wire Strain Gauge is designed to be installed on the surface of steel structures or other buildings to measure structural strains. Temperature expansion coefficient of the instrument is the same as that of the steel structure to measure, and is very close to that of concrete as well. Therefore, temperature correction is seldom needed. Meanwhile, the built-in temperature sensor can monitor temperature at the position where the instrument is installed if it is necessary. Made of stainless steel, the Vibrating Wire Strain Gauge features extremely high precision and sensitivity, excellent waterproofness, corrosion resistance, and long-term stability. Frequency and temperature resistance signals are transferred through dedicated four-core shielded cables, and frequency signals will not be affected by the length of cables. This instrument can be used to perform long-term strain alteration monitoring on buildings in harsh environment. Since model CGEO-SG2 has mounting blocks, you can use it used as a steel plate stress gauge directly.

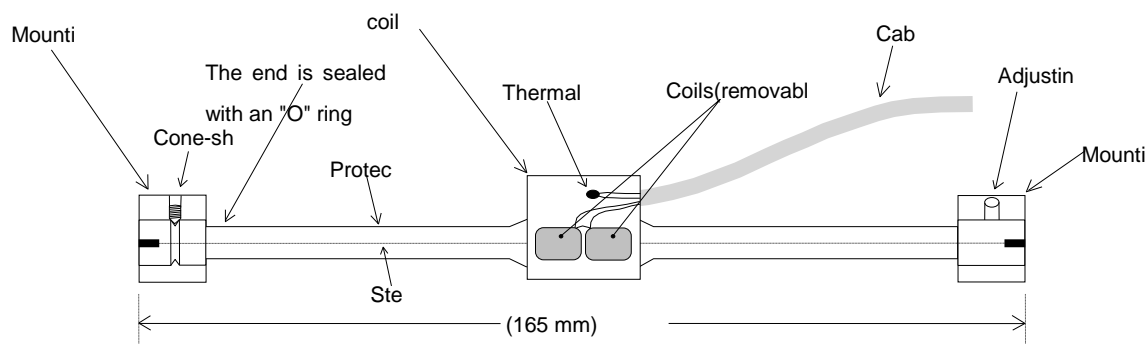

Figure 1 - Structure of CGEO-SG2 Strain Gauge

2. INSTRUMENT INSTALLATION

After the instruments are installed in place, you should record their readings, positions and numbers. Adjustment (if necessary) should be handled with care in order to make its monitoring range meet design requirements.

2.1. Initial Inspection

When you perform acceptance check, you should check readings of the instrument against the rating table and record the results.

2.2. Installing the CGEO-SG2 Strain Gauge

CGEO-SG2 Strain Gauges are usually used to measure strains on the surface of a structure. If you want to install a CGEO-SG2 Strain Gauge on a steel structure, welding its mounting blocks is the most common method. Never permit welding current to pass through any sensor, or that sensor will be damaged. Therefore, you should not install any sensor before the welding procedure is finished. Use a 165mm-long mounting rod with the diameter of 12mm (It is made of round steel. You can produce by yourself or order from the manufacturer.) to locate and weld those mounting blocks. Mounting blocks are provided in pairs with cone-shaped set screws. The surface for welding should be cleaned up. Firstly, thread each end of the rod through a mounting block. After you aligned both ends, fix the mounting block at each end by tightening appropriate screws. Then put the assembly in the appointed position. Figure 2 shows welding positions and order:

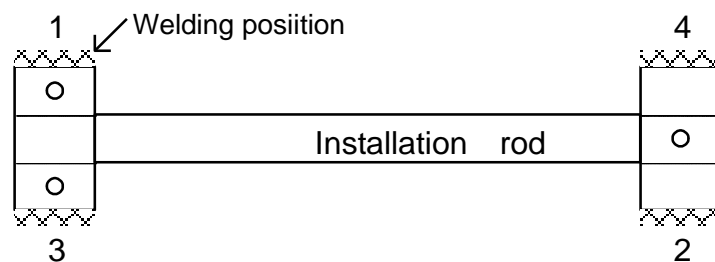
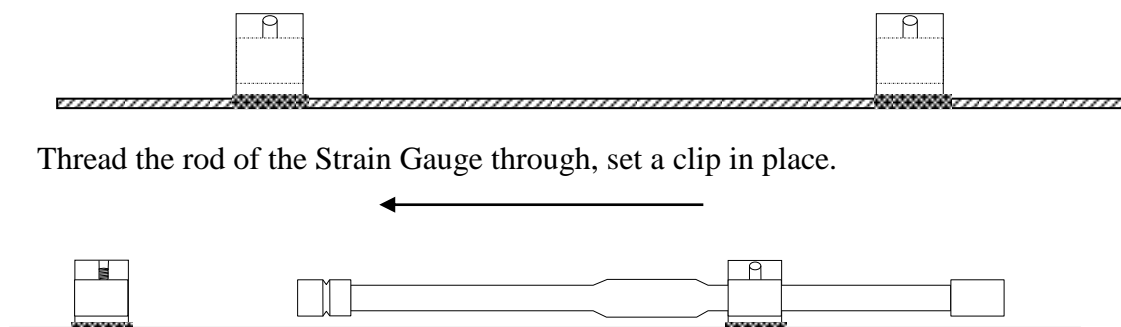
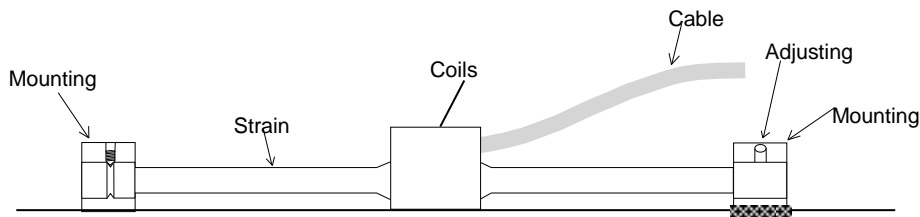

Figure 2 - Welding Positions and Order for a Mounting Block

When you are welding, prevent the instrument becoming too hot. Do not weld the flat face, or the removing and assembling tasks will be affected. When welding procedure is finished, decrease the temperature of mounting blocks by an appropriate method, remove welding spatters. After mounting blocks have been cooled, remove the mounting rod.



Position a coil in the middle of the Strain Gauge, set a clip around the coil and tighten it.



Fix the end with a V groove of the Strain Gauge by screws, adjust the other end to get the expected initial reading, then fix it by screws.

Important: Never perform welding directly after you fixed the Strain Gauge and mounting blocks. Otherwise, it is extremely possible that welding current would pass through the steel wire and cause the Strain Gauge damaged. We assumes no responsibility for any instrument damage caused by violating the operation steps above!

If the instrument needs protection, you can weld two screws before installing the instrument to install protective cover (cover made of channel steel is recommended). The distance between any bolt and the Strain Gauge should $\geq 150\text{mm}$. See the figure below for reference:

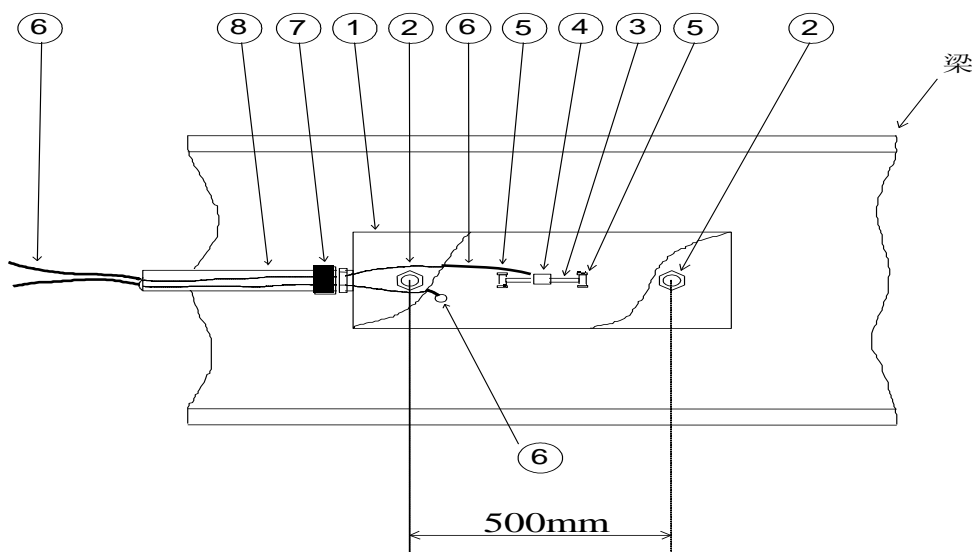

- | | | |
|--------------------------------------|--|-----------------------------|
| 1. Protective cover | 2. Bolts | 3. Strain Gauge |
| 4. Exciting coil of the Strain Gauge | 5. Mounting blocks of the Strain Gauge | |
| 6. Instrument's cable | 7. protection tube fittings | 8. Flexible protection tube |

Figure 3 Installing the Instrument on a Surface of a Steel Structure and Its Protection

If grouting or waterproofing is necessary, you can use emulsified asphalt (or waterproof filler) to enwrap or block the protective cover section to prevent mortar or water from entering.

CGEO-SG2 Strain Gauge can also measure strains on the surface of concrete. Install the

Strain Gauge on the surface of concrete through the following method:

1. Weld anchor shanks on mounting blocks, and locate with the mounting rod at the same time. Drill two holes with the depth of 60mm at the appropriate positions, the diameter of those holes could not less than 12.5mm (depending on the diameter of each anchor shank). Fix anchor heads in those holes with rapid setting mortar or epoxy mortar. See the figure below for reference:

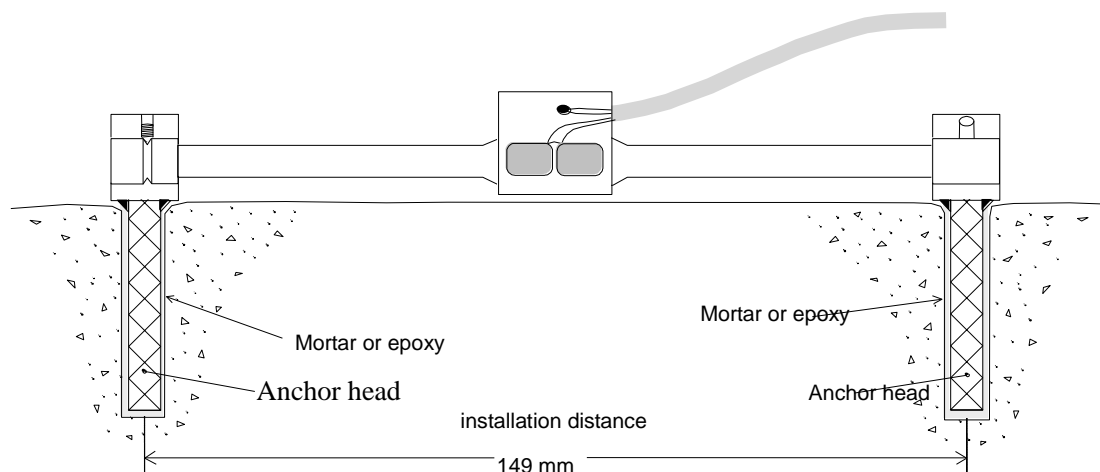

Figure 4 Installing the Instrument on Concrete with Grouting Anchor Heads

2. A standard mounting block could be fastened onto the surface of concrete directly with epoxy, if only you have taken perfect protection. We recommend you to use Loctite 410 and accelerating agent. With extremely high bonding strength and bonding speed, that combination is quite suitable for quick installation of the instrument. If you choose this method, you should clean up the position to install the instrument (such as remove sands), and wash it thoroughly. After you locate the instrument with the mounting rod, we still recommend you to glue it.

2.3. Adjusting the Strain Gauge

After you fixed mounting blocks in place, remove the mounting rod, install the instrument and coil, and then tighten screws at the fixed end of the instrument (Cone-shaped set screws should enter into the groove on the grooved end of the instrument.). Adjust the instrument when it is being monitored by the Readout. The normal range of the readings displayed on the CGEO-SG2 Strain Gauge (at CGEO-PR-VW "C" level) is 400~1200 (Digits). If the instrument is designed to measure tension strains, press the movable end of the Strain Gauge

inward lightly (avoid relative torsion or the Strain Gauge will be damaged), and adjust the reading to around 650. If the instrument is designed to measure compression strains, press the movable end of the Strain Gauge outward lightly and adjust the reading to around 950. After adjusting, fix the movable end.

2.4. Notice

Cables can be casted in concrete directly. In order to provide better protection, you would better use cable protection tubes. You can use dedicated heat shrinkable joints to connect and lengthen a cable. For specific models, please contact CGEO INTERNATIONAL LIMITED.

The place to lay cables should be far away from any electrical noise source, such as power line, generator, motor, transformer, arc welder, and so on. If it is necessary, you can consult CGEO INTERNATIONAL LIMITED. about the selection of suitable filters.

2.5. Thunder-proof Protections

Here are some available thunder-proof protections:

- 1) If you are using a portable Readout to read manually, always ground the cables soundly, and it is the simplest thunder-proof method.
- 2) If you are ordering connection box from CGEO INTERNATIONAL LIMITED., you can order the built-in thunder-proof protection at the same time. There're two protection levels available:
 1. A plasma surge arrester has been installed on every terminal block.
 2. Terminal box can be place into arrester board which could provide further protection for the instrument by a surge arrester and transzorbs.

3. READINGS AND COMPUTATION

You should use the CGEO-PR-VW Readout with the CGEO-SG2 Strain Gauge. When you are measuring, please use level "C" to display readings. The CGEO-D6 or D7 Data Acquisition System is also permitted.

The following formula is used to compute strains:

$$\varepsilon \text{ (microstrain)} = G \times C \times (R_1 - R_0)$$

Where: G is the standard coefficient of the instrument

C is the averaged correction coefficient

R_1 is the current reading (Digits)

R_0 is the initial reading (Digits)

For temperature coefficient of the instrument and its correction on temperature factors, please refer to the rating table.

4. STRAIN-STRESS CONVERSION

Because designers always prefer structural load or stress measurements, while what we can get from a Strain Gauge are strains or structural distortion, it is necessary to convert strains measured to stresses. Let's suppose the structural distortion is elastic deformation, and the influence of any bending moment will be ignored, then we'll get:

$$\text{Stress } \sigma = \text{Strain } \varepsilon \times \text{Elastic modulus } E$$

Formula 1 - Stress Computation

If you consider the influence of bending moments, you should deploy certain number of instruments evenly along axis of the structure. For a columnar pile brace, you should set three Strain Gauges (four will be better) around the brace, and the angle between those gauges is 120° . For a H-shaped pile and I-shaped girder, you'll need to set 4 Strain Gauges at least. If it is a steel plate pile, there should be two Strain Gauges symmetrically installed on both sides of the pile. If a steel component is bending and you can only touch its front surface, such as the steel plate lining of a tunnel or the outer-face of a steel plate pile, you can measure its bending moments by installing two Vibrating Wire Strain Gauges at different positions not far from the neutral axis.

Look at the I-shaped girder sample in Figure 5A. There're four Strain Gauges (1, 2, 3, 4) welded in the center web of the I-shaped girder. Those gauges are divided into two groups evenly which stand back to back. The position where the Strain Gauges are installed is higher than the center web of the I-shaped girder, and the difference between them is d . The distance between those two groups is $2c$. The I-shaped girder has two flanges with the width of $2b$. The depth of the web is $2b$.

Average a set of strain values of those 4 Strain Gauges, and multiply the result by elastic

modulus, then you'll get a axial stress.

$$\sigma_{\text{axial}} = \frac{(\varepsilon_1 + \varepsilon_2 + \varepsilon_3 + \varepsilon_4)}{4} \times E$$

Formula 2 - Axial Stress Computation

The difference between readings of the two Strain Gauges standing opposite each other on the neutral axis is just the bending moment. The maximum bending moment of axis yy is:

$$\sigma_{yy} = \frac{(\varepsilon_1 + \varepsilon_3) - (\varepsilon_2 + \varepsilon_4)}{4} \times \frac{b}{d} \times E$$

Formula 3 - Stress Caused by Bending of Axis YY

The maximum bending moment of axis xx is:

$$\sigma_{xx} = \frac{(\varepsilon_1 + \varepsilon_2) - (\varepsilon_3 + \varepsilon_4)}{4} \times \frac{a}{c} \times E$$

Formula 4 - Stress Caused by Bending of Axis XX

$$\sigma_{\text{maximum}} = \sigma_{\text{axial}} + \sigma_{xx} + \sigma_{yy}$$

Formula 5 - The Maximum Stress

Please make sure that you are using the correct "+" or "-" sign for a stress in all of the computation above.

Note: At any point within a junction, its total strain is the algebraic sum of strain caused by bending moments and axial strain. Through observation we know, the strain at an exterior angle of a flange is much higher than that of the web, and local failure may come into being from such places. So, analysis of bending moments is very important.

Through analysis above we know, Strain Gauges should be welded at corners of those flanges (see Figure 5B) to get the most accurate readings. However, welding Strain Gauges at these positions also has prominent disadvantages: instrument protection will become difficult,

cables are subject to damage. And it could cause another problem with more severe results for applications in real-world: Strain Gauges will be affected greatly by bending moments. Therefore, it is a more suitable solution to weld Strain Gauges at both sides of the neutral axis of web of the I-shaped girder (see Figure 5A). In this situation, instrument protection will be more easier too.

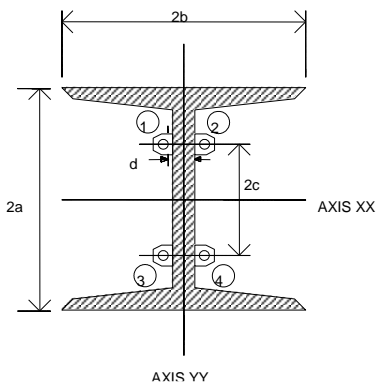

Figure 5A - Strain Gauges Installed at Center Web

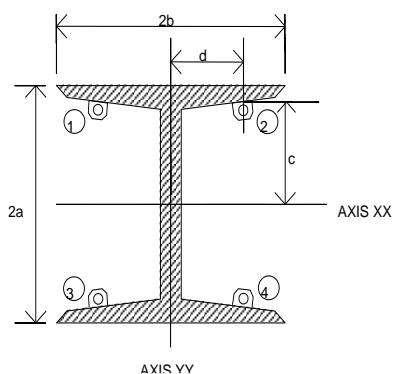

Figure 5B - Strain Gauges Installed at a Flange

If you determined to use only 2 gauges on each cross section for economic reasons, you can deploy them as Figure 8C, and you'll get axial strains and bending moments about axis YY.

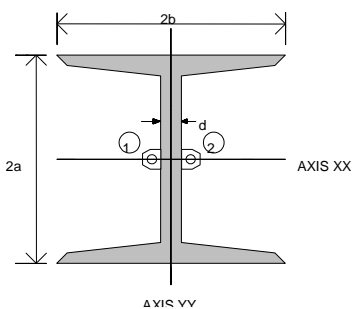

Figure 5C - Axial Strain Measurement

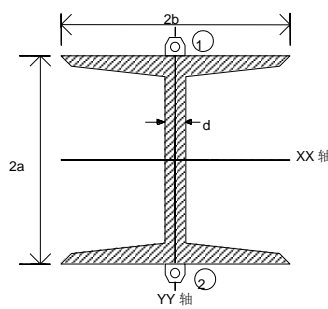

Figure 5D - Axial Strains and bending moments about axis YY

This kind of layout has an useful advantage: it makes the protection for instruments and cables more easier. In fact, cables from instruments can pass through holes on the web, so that

two cables will pass a single pipe and that makes protection easier.

There're other layouts for those two instruments which have been proven to be successful, please refer to Figure 5D.

You can get axial strains and bending moments about axis XX from this layout. But it also has a disadvantage: instruments will be exposed outside of flanges. That calls for greater protection for instruments and cables.

5. TROUBLESHOOTING

If there's any questionable reading, please take the following steps:

Firstly, check coil resistance, which should be equal to $180 \pm 10\Omega$ plus cable resistance normally. (Wire resistance of a suitable standard cable is about $50\Omega/\text{km}$.)

- a) If the resistance is too high or infinite, you should suspect the cable is in open circuit condition.
- b) If the resistance is too low or close to 0, you should suspect the cable is in short circuit condition.
- c) If the resistance is normal, while no sensor displays a reading, you should suspect something is wrong with the Readout. Please contact the manufacturer as soon as possible.
- d) If all resistances are normal, while only one sensor does not display any reading, you should suspect something is wrong with this sensor. Please contact the manufacturer as soon as possible.

If you discover that the cable is in open circuit or short circuit condition, please re-connect it per standard instructions.

APPENDIX A - SPECIFICATIONS

A. 1 Strain Gauge

Range (rating):	3000 $\mu\epsilon$
Resolution:	0.1 $\mu\epsilon$ ¹
Accuracy:	1.0% FSR ²
Stability:	0.1%FS/year
Linearity:	2.0% FSR
Temp. Coefficient:	12.2 $\mu\epsilon/^\circ\text{C}$
Instrument Size:	6.125 × 0.750"
Coil Size:	0.875 × 0.875"
Coil Resistance:	150 Ω
Temp. Range:	-20 to +80° C

Note: 1. It is dependent on the Readout used. This number is measured by the CGEO-PR-VW Readout.

2. Its accuracy could reach 0.5%FSR after calibrating by single.

A.2 Thermal Resistor (See Appendix B)

Range: -80—150°C
Accuracy: $\pm 0.5^\circ\text{C}$

APPENDIX B –

TEMPERATURE COMPUTATION FORMULA FOR SEMICONDUCTOR THERMOMETER

Semiconductor Thermometer types: YSI 44005, Dale # 1C3001-B3, Alpha # 13A3001-B3

Formula for converting resistance to temperature:

$$T = \frac{1}{A + B(\ln R) + C(\ln R)^3} - 273.2$$

Semiconductor Thermometer's Resistance-temperature Converting Relation

Where: T=Celsius temperature

LnR =Napierian logarithm of resistance

A=1.4051 × 10⁻³ (The computation is valid within the range of -50 to +150°C.)

B=2.369 × 10⁻⁴

C=1.019 × 10⁻⁷

Resistanc e(Ω)	Temperat ure °C	Resistanc e(Ω)	Temperat ure °C	Resistanc e(Ω)	Temperat ure °C	Resistanc e(Ω)	Temperat ure °C	Resistanc e(Ω)	Temperat ure °C
201.1K	-50	16.60K	-10	2417	+30	525.4	+70	153.2	+110
187.3K	-49	15.72K	-9	2317	31	507.8	71	149.0	111
174.5K	-48	14.90K	-8	2221	32	490.9	72	145.0	112
162.7K	-47	14.12K	-7	2130	33	474.7	73	141.1	113
151.7K	-46	13.39K	-6	2042	34	459.0	74	137.2	114
141.6K	-45	12.70K	-5	1959	35	444.0	75	133.6	115
132.2K	-44	12.05K	-4	1880	36	429.5	76	130.0	116
123.5K	-43	11.44K	-3	1805	37	415.6	77	126.5	117
115.4K	-42	10.86K	-2	1733	38	402.2	78	123.2	118
107.9K	-41	10.31K	-1	1664	39	389.3	79	119.9	119
101.0K	-40	9796	0	1598	40	376.9	80	116.8	120
94.48K	-39	9310	+1	1535	41	364.9	81	113.8	121
88.46K	-38	8851	2	1475	42	353.4	82	110.8	122
82.87K	-37	8417	3	1418	43	342.2	83	107.9	123
77.66K	-36	8006	4	1363	44	331.5	84	105.2	124
72.81K	-35	7618	5	1310	45	321.2	85	102.5	125
68.30K	-34	7252	6	1260	46	311.3	86	99.9	126
64.09K	-33	6905	7	1212	47	301.7	87	97.3	127
60.17K	-32	6576	8	1167	48	292.4	88	94.9	128
56.51K	-31	6265	9	1123	49	283.5	89	92.5	129
53.10K	-30	5971	10	1081	50	274.9	90	90.2	130
49.91K	-29	5692	11	1040	51	266.6	91	87.9	131
46.94K	-28	5427	12	1002	52	258.6	92	85.7	132
44.16K	-27	5177	13	965.0	53	250.9	93	83.6	133
41.56K	-26	4939	14	929.6	54	243.4	94	81.6	134
39.13K	-25	4714	15	895.8	55	236.2	95	79.6	135
36.86K	-24	4500	16	863.3	56	229.3	96	77.6	136
34.73K	-23	4297	17	832.2	57	222.6	97	75.8	137
32.74K	-22	4105	18	802.3	58	216.1	98	73.9	138
30.87K	-21	3922	19	773.7	59	209.8	99	72.2	139
29.13K	-20	3748	20	746.3	60	203.8	100	70.4	140
27.49K	-19	3583	21	719.9	61	197.9	101	68.8	141
25.95K	-18	3426	22	694.7	62	192.2	102	67.1	142
24.51K	-17	3277	23	670.4	63	186.8	103	65.5	143
23.16K	-16	3135	24	647.1	64	181.5	104	64.0	144
21.89K	-15	3000	25	624.7	65	176.4	105	62.5	145
20.70K	-14	2872	26	603.3	66	171.4	106	61.1	146
19.58K	-13	2750	27	582.6	67	166.7	107	59.6	147
18.52K	-12	2633	28	562.8	68	162.0	108	58.3	148
17.53K	-11	2523	29	543.7	69	157.6	109	56.8	149
								55.6	150

Semiconductor Thermometer's Resistance-Temperature Look-Up Table