

Applications

The Model CGEO-SG6 Strandmeter is designed to measure strains in tendons and steel cables, including bridge tendons, cable stays, ground anchors, tiebacks, etc. Two clamps at each end of the strandmeter hold it firmly onto the cable. Various size clamps are available.

Description

The Model CGEO-SG6 Strandmeter is designed to measure change in deformation in wire strands such as those that are commonly used in tiebacks and earth anchors.

The instrument consists of a vibrating wire sensing element and a stress relieved spring which is connected to the wire at one end and a connecting rod at the other.

As the connecting rod is pulled out from the gage body, the spring is elongated causing an increase in tension, which is sensed by the vibrating wire element. The tension in the wire is directly proportional to the extension; hence, the change in deformation can be determined very accurately by measuring the strain change with the vibrating wire readout box.

Key Features

- ◆ Accurate, long-term stability
- ◆ Robust design and reliable
- ◆ Waterproofing
- ◆ Fit for manual or remote reading
- ◆ integral thermistor
- ◆ Gages and coils are re-usable

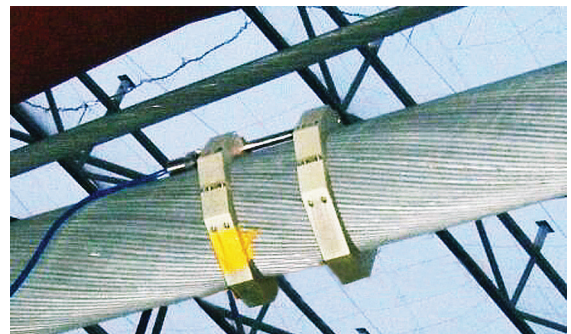

Comprehensive information about this product and our full range is available at www.cgeo-instruments.com
If you would prefer to speak with someone directly, please call +852 2206 0092 or email info@cgeo-instruments.com

Main Specifications

Model	CGEO-SG6
Range	20000 $\mu\epsilon$ / 50000 $\mu\epsilon$
Resolution	0.01% F.S.
Accuracy	$\pm 0.1\%$ F.S.
Temperature Range	-20 to ~ + 80 °C
Waterproof	Customized

Operation

The Model CGEO-SG6 Strandmeters are using vibrating wire displacement transducers to measure displacements across joints and cracks, in essence, the transducer consists of a vibrating wire in series with a tension spring. Displacements are accommodated by a stretching of the tension spring, which produces a commensurate increase in wire tension.

The wire and spring are connected to a free-sliding rod which protrudes from, and is free to slide inside, a protective outer tube. An O-ring seal prevents water from entering.

The frequency signal is transmitted through the cable to the readout location, conditioned, and displayed on portable readouts or dataloggers.

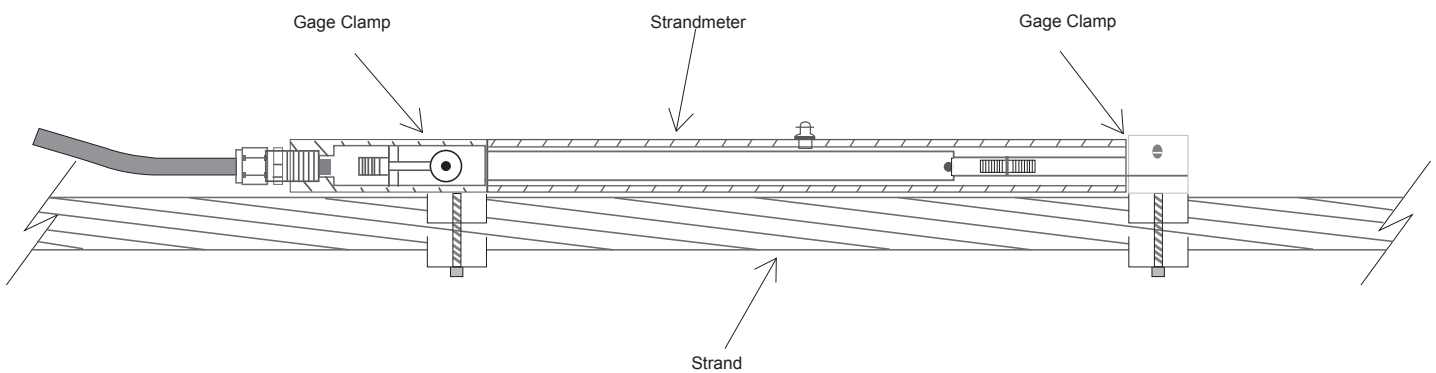

International Manufacturer of Geotechnical & Structural Instruments

CGEO INTERNATIONAL LIMITED
 Room 06, 13A/F., South Tower,
 World Finance Centre, Harbour City, 17
 Canton Road, Tsim Sha Tsui, Kowloon, Hong Kong.

Tel: +852 2206 0092
 Fax: +852 3003 0133
 Http: //www.cgeo-instruments.com
 Email: info@cgeo-instruments.com

CGEO INTERNATIONAL LIMITED Registered Office: Room 06, 13A/F., South Tower, World Finance Centre, Harbour City, 17 Canton Road, Tsim Sha Tsui, Kowloon, Hong Kong.