



Applications

The Model CGEO-LL1 Liquid Level System consists of a series of vessels containing liquid level sensors interconnected by a liquid filled tube. A reference vessel is positioned at a stable location with observation vessels positioned at different locations at approximately the same elevation. It is suitable for settlement monitoring, including road/railway subgrades, bridges, tunnels, dams, foundation pits, building foundations.

Description

The CGEO-LL1 Liquid Level Sensor is based on Vibrating Wire Sensor which is particularly suitable for critical situations where high resolution is required. Settlements as small as 0.01 mm are detectable.

Key Features

- ◆ Accurate and precise measurements using Vibrating Wire sensors
- ◆ Very high resolution
- ◆ Robust design and reliable
- ◆ In-built temperature compensation

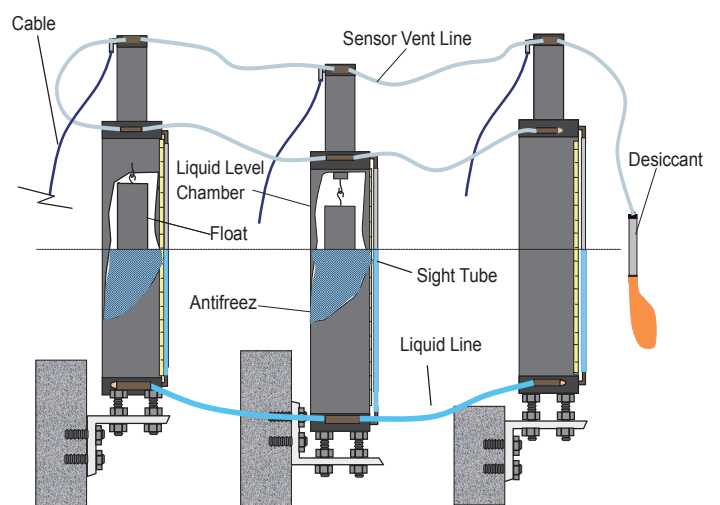

Comprehensive information about this product and our full range is available at www.cgeo-instruments.com
 If you would prefer to speak with someone directly, please call +852 2206 0092 or email info@cgeo-instruments.com

Main Specifications

Model	CGEO-LL1				
Range	50mm	100mm	150mm	300mm	600mm
Resolution	0.025% F.S.				
Accuracy	±0.1% F.S.				
Temperature Range	-20 to + 80°C				

Operation

This system is particularly suitable for critical situations where high resolution is required.

A series of vessels are interconnected by a liquid-filled tube. One reference vessel is located on stable ground and the other vessels are located at the points of settlement. Each vessel contains a cylindrical weight suspended from a vibrating wire transducer. The common liquid level inside each vessel partially submerges the hanging weights; settlement of a vessel causes an apparent rise of the water level in that vessel leading to a greater buoyancy force on the weight and a reduction in the tension and frequency of the vibrating wire.

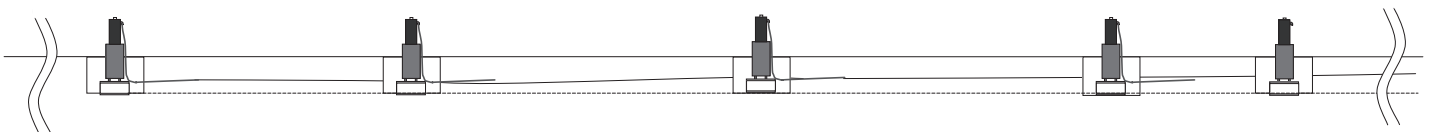
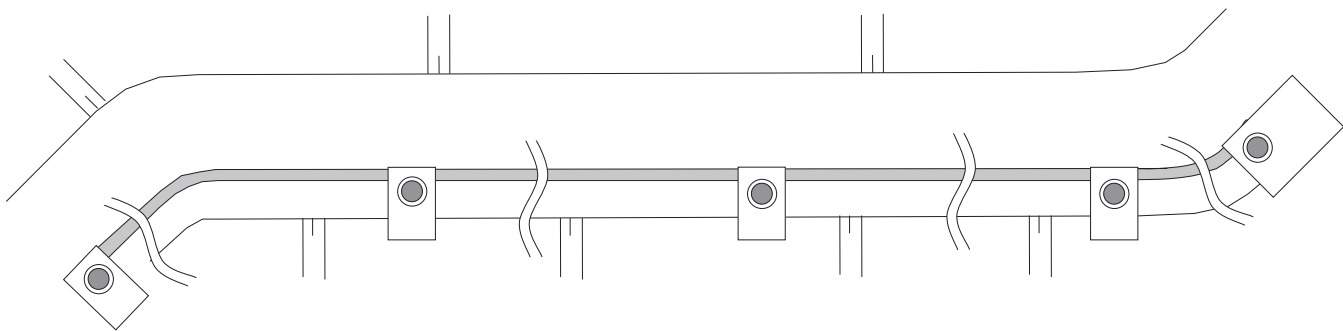
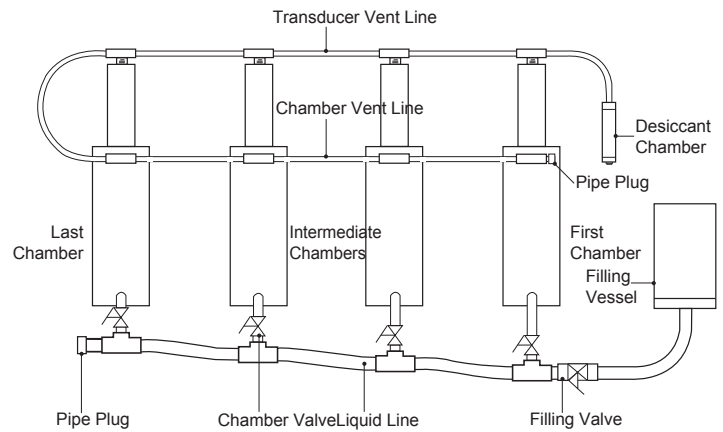

International Manufacturer of Geotechnical & Structural Instruments

CGEO INTERNATIONAL LIMITED
 Room 06, 13A/F, South Tower,
 World Finance Centre, Harbour City, 17
 Canton Road, Tsim Sha Tsui, Kowloon, Hong Kong.

Tel: +852 2206 0092
 Fax: +852 3003 0133
 Http: //www.cgeo-instruments.com
 Email: info@cgeo-instruments.com

CGEO INTERNATIONAL LIMITED Registered Office: Room 06, 13A/F, South Tower, World Finance Centre, Harbour City, 17 Canton Road, Tsim Sha Tsui, Kowloon, Hong Kong.