



Applications

The Model CGEO-LL2 Liquid Level System consists of a series of vessels containing liquid level sensors interconnected by a liquid filled tube. A reference vessel is positioned at a stable location with observation vessels positioned at different locations at approximately the same elevation. It is suitable for settlement monitoring, including road/railway subgrades, bridges, tunnels, dams, foundation pits and building foundations.

Description

The output of CGEO-LL2 Liquid Level Sensor is RS485 (MODBUS) digital signal, so each sensor is connected to each other by means of a four-wire bus cable.. The same cable (customer specified

length) connects the uppermost sensor to the chosen readout (PC or datalogger, system, etc.)

Key Features

- ◆ Accurate and precise measurements using Magnetostrictive sensors
- ◆ Robust design and reliable
- ◆ In-built temperature compensation
- ◆ One single four-wire bus cable to connect each sensor to the dataloggers



Comprehensive information about this product and our full range is available at www.cgeo-instruments.com
If you would prefer to speak with someone directly, please call +852 2206 0092 or email info@cgeo-instruments.com

Main Specifications

Model	CGEO-LL2			
Range	100mm	200mm	300mm	500mm
Resolution	0.01% F.S.			
Accuracy	±0.1% F.S.			
Temperature range	-20 to +60°C			
Dia.	112mm (sensor)			
Height	350mm	450mm	550mm	750mm

Operation

This system is particularly suitable for critical situations where need high resolution and big measuring range are required.

A series of vessels are interconnected by a liquid-filled tube. One reference vessel is located on reference point (such as stable ground) and the other vessels are located at the points of settlement. The settlement or elevation of monitored points is reflected by measuring the change of the liquid level of the points of settlement relative to the reference point.

The sensor has high sensitivity and good stability, and is not affected by changes in ambient temperature. The system uses a fully sealed internal pressure self-balancing system that is not affected by changes in atmospheric pressure. It is suitable for use in harsh environments with antifreeze.



The vent line and liquid line are all equipped with quick joints to facilitate the user to assemble and debug on site. The supporting mounting brackets allow the user to fix on the wall or the ground. The output of the system is RS485 (MODBUS) signal.

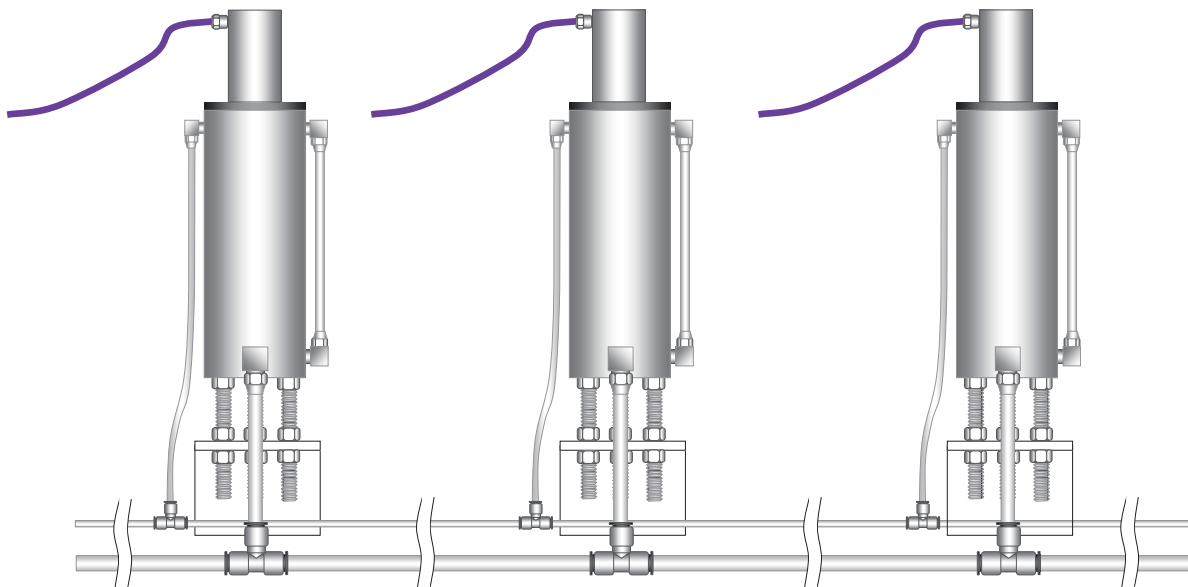

International Manufacturer of Geotechnical & Structural Instruments

CGEO INTERNATIONAL LIMITED
 Room 06, 13A/F., South Tower,
 World Finance Centre, Harbour City, 17
 Canton Road, Tsim Sha Tsui, Kowloon, Hong Kong.

Tel: +852 2206 0092
 Fax: +852 3003 0133
 Http: //www.cgeo-instruments.com
 Email: info@cgeo-instruments.com

CGEO INTERNATIONAL LIMITED Registered Office: Room 06, 13A/F., South Tower, World Finance Centre, Harbour City, 17 Canton Road, Tsim Sha Tsui, Kowloon, Hong Kong.